



Engine YANMAR 4TNV98T

Type	Diesel, 4 Stroke
Cooling system	Water
Cylinders	4
Displacement (c.c. - cu.in)	3108 - 189,4
Engine output (hp)	54,7
RPM	1500
Injection system	Direct
Governor	Mechanical
Lubrication system	Forced
Oil sump capacity (L - gal)	10 - 2,2
Stop system	Solenoid
Fuel tank capacity (L - gal)	50 - 13,1
Autonomy 3/4 load (h)	8,9
Starter battery (Ah-V)	80 -12
Battery charger (Ah-V)	30 -12
Starter motor (kW-V)	1,4 / 12

Generator

Type	Brushless, Synchronous, 4 poles, selfexcited
Regulation	Electronic
Voltage (V)	400 / 230
Frequency (Hz)	50
<b>3-Phase data</b>	
Voltage (V)	400
Max. output (kVA)	44
Cont.output (kVA)	40
Power factor (cos $\phi$ )	0,8
<b>Single-Phase data</b>	
Voltage (V)	230
Max. output (kVA)	14,7
Power factor (cos $\phi$ )	1
Insulation class	H
Voltage stability	$\pm 2\%$
Frequency stability	$\pm 2,5\%$

### Soundproof cabin

- With frame and openable hoods made of steel panels and epoxidic paint.

### Engine

- Easy access in case of maintenance to the feeding system, lubrication system and air filter.
- Safety stop in case of low oil pressure.
- Safety stop in case of high water temperature.
- Oil and fuel filters are easily accessible and easily replaceable.
- Oil cooled engine with radiator.

### Control panel

- The **mase** control panel for manual starting and stopping has been designed and built to combine all the control instruments and warning lights and protections both for the engine and the generator.
- Control panel is made of painted steel plate and include the following main equipment:
  - Voltmeter • 4-pole circuit breaker and earth fault device • 3-pole magnetothermal switch 16A • 1-pole magnetothermal switch 16A
  - Electronic device for automatic shutdown of the engine in case of HWT and LOP • Emergency stop pushbutton • Ignition key • Warning light for high cooling water temperature and low oil pressure • Hourmeter
  - Socket 63A 400V 3P+N+G • Socket 16A 400V 3P+G
  - N°2 Sockets 2P+G 230V 16A

### Generator

- Synchronous, 4 poles, self-excited
- Rotor and stator epoxidic resin coated against environmental agents.
- Rotor dynamically balanced.
- Insulation class H

# MPF 44

## STANDARD version (BA)

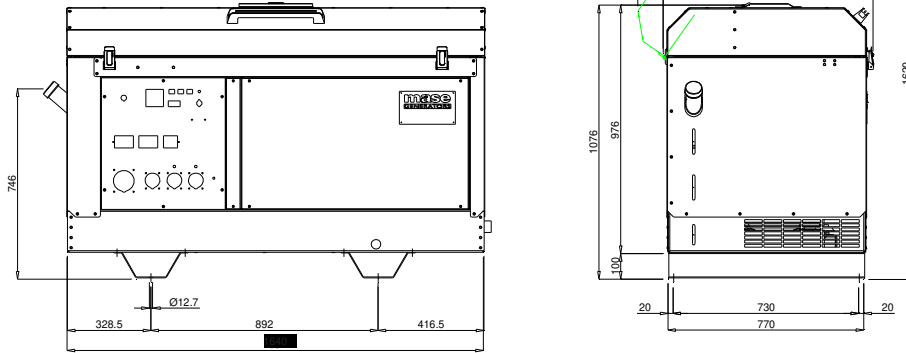

## FIXED TOW version (TF)

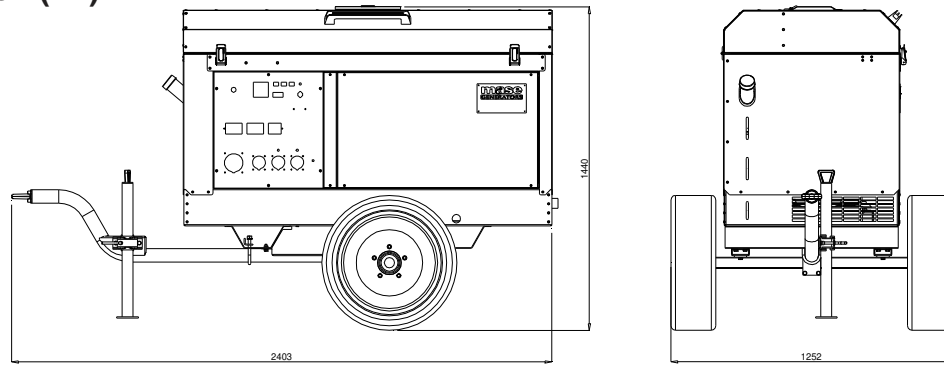

## Automatic control panel and transfer switch version

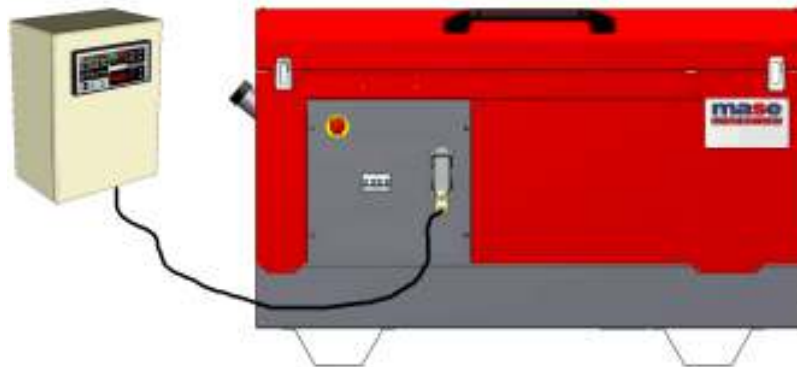

	MPF 44 BA	MPF 44 TF	
Lenght	1640 - 64,5	2403 - 94,5	mm - in
Width	770 - 30,3	1252 - 49,3	mm - in
Heigh	1076 - 42,4	1440 - 56,7	mm - in
Weight	830 - 1844	860 - 1911	kg - lbs
<b>Noise power level 97 LwA</b>			

Dealer:

## OPTIONALS: SITE TOW VERSION

*This drawing is only a reference and is not indicatly for the installation.  
For more information, you may contact your local dealer or **mase** generators S.p.A.*

**mase** generators S.p.A. reserves the right to change the design or specifications without notice and without any obligations or liability whatsoever  
For more information, you may contact your local **mase** dealer.