



YANMAR

mase
GENERATORS

MPF 33

Max Power 33kVA



Engine YANMAR 4TNV98

Type	Diesel, 4 Stroke
Cooling system	WATER
Cylinders	4
Displacement (c.c.)	3319
Engine output (hp)	47
RPM	1500
Injection system	Direct
Governor	Mechanical
Lubrication system	Forced
Oil sump capacity (L - gal)	10 - 2,2
Stop system	Solenoid
Fuel tank capacity (L - gal)	50 - 13,1
Autonomy 3/4 load (h)	9,5
Starter battery (Ah-V)	80 -12
Battery charger (Ah-V)	30 -12
Starter motor (kW-V)	1,4 / 12

Generator

Type	Brushless, Synchronous, 4 poles, selfexcited
Regulation	Electronic
Voltage (V)	400 / 230
Frequency (Hz)	50
3-Phase data	400 V
Max. output	33 kVA
Cont.output	30 kVA
Power factor (cos ϕ)	0,8
Insulation class	H
Voltage stability	$\pm 2\%$
Frequency stability	$\pm 2,5\%$

Soundproof cabin

- With frame and openable hoods made of steel panels and epoxidic paint.

Engine

- Easy access in case of maintenance to the feeding system, lubrication system and air filter.
- Safety stop in case of low oil pressure.
- Safety stop in case of high water temperature.
- Oil and fuel filters are easily accessible and easily replaceable.
- Oil cooled engine with radiator.

Control panel

- The **mase** control panel for manual starting and stopping has been designed and built to combine all the control instruments and warning lights and protections both for the engine and the generator.
- Control panel is made of painted steel plate and include the following main equipment:
 - Voltmeter • 4-pole circuit breaker and earth fault device • 3-pole magnetothermal switch 16A • 1-pole magnetothermal switch 16A
 - Electronic device for automatic shutdown of the engine in case of HWT and LOP • Emergency stop pushbutton • Ignition key • Warning light for high cooling water temperature and low oil pressure • Hourmeter
 - Socket 63A 400V 3P+N+G • Socket 16A 400V 3P+G
 - N°2 Sockets 2P+G 230V 16A

Generator

- Synchronous, 4 poles, self-excited
- Rotor and stator epoxidic resin coated against enviromental agents.
- Rotor dynamically balanced.
- Insulation class H.



Your partner in power solutions - Worldwide delivery

MPF 33



STANDARD version

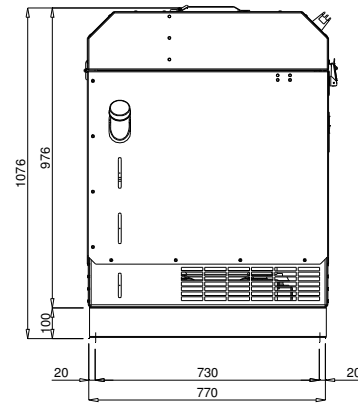
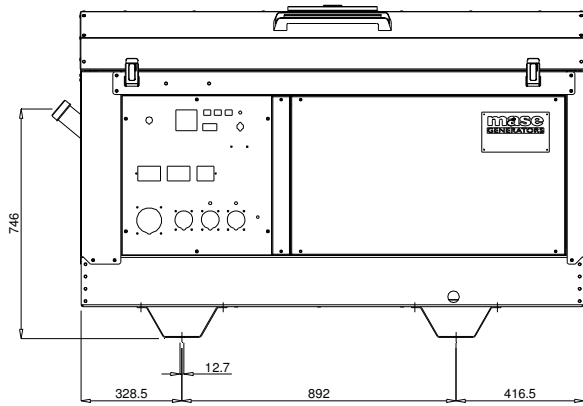

FIXED TOW version

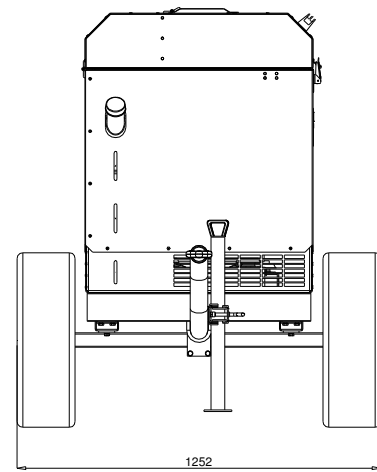
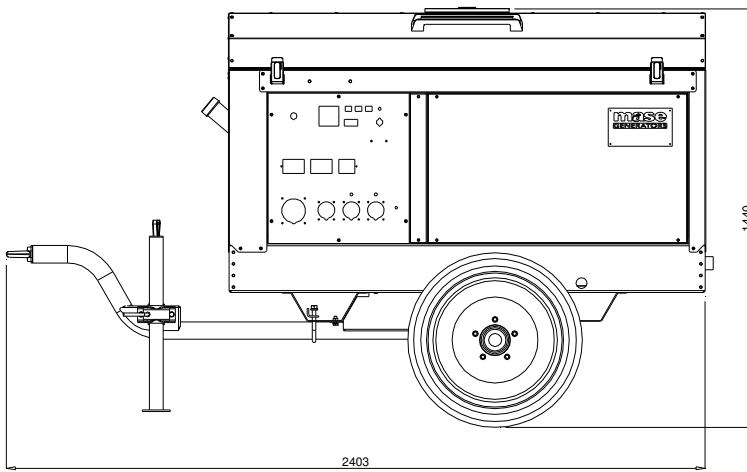

Automatic control panel and transfer switch version

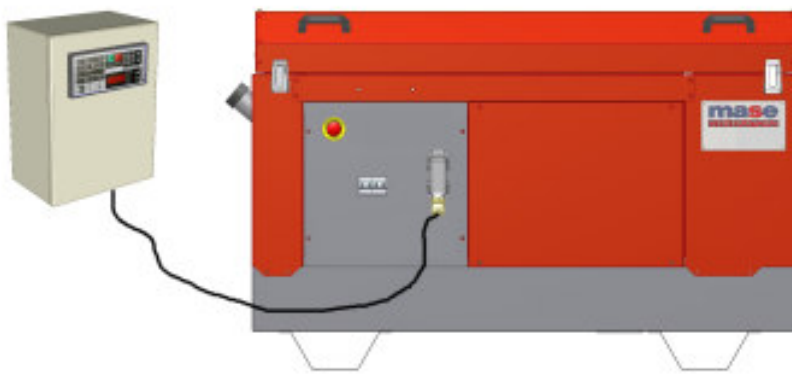

	MPF 33 BA	MPF 33 TF	
Lenght	1640 - 64,5	2403 - 94,5	mm - in
Width	770 - 30,3	1252 - 49,3	mm - in
Heigh	1076 - 42,4	1440 - 56,7	mm - in
Weight	830 - 1844	860 - 1911	kg - lbs
Noise power level 97 LwA			

OPTIONALS:

SITE TOW VERSION

This drawing is only a reference and is not indicatly for the installation.
For more information, you may contact your local dealer or **mase** generators S.p.A.

mase generators S.p.A. reserves the right to change the design or specifications without notice and without any obligations or liability whatsoever
For more information, you may contact your local **mase** dealer.

Dealer:



Your partner in power solutions - Worldwide delivery